



WWW.FYICHINA.COM.CN

WENZHOU FANGYUAN INSTRUMENT CO., LTD.
DOWELL SCIENCE AND TECHNOLOGY (HONGKONG) CO., LTD.
ADD: ROOM 1401 CAMBRIDGE HOUSE, 26-28 CAMERON ROAD,
TSIMSHATSUI, KL, HONGKONG
TEL: +86-755-83638931
Fax: +86-755-26747651

OPERATION OF YG511-III

CONTENTS

1 INTRODUCTION	2
2. TEST METHOD	2
2.1 ORBITER METHOD	2
2.2 MARTINDALE METHOD:.....	3
2.3 IMPULSE METHOD	3
3 PREPARATION OF TEST SPECIMENS	4
3.1 CUTTING OUT	4
3.2 NUMBER OF TEST SPECIMENS	4
3.3 MOUNTING OF TEST SPECIMENS	4
3.4 CONDITIONING	5
4. TEST PROCEDURE	5
4.1 CHECKING	5
4.2 LOADING SPECIMEN	5
4.3 POWER SUPPLY	6
4.4 PARAMETER SETTING.....	6
4.4.1 Counts reset	6
4.4.2 Time preset	6
4.5 NOTES	7
4.6 UNLOAD.....	7
5. ASSESSMENT OF FUZZING AND/OR PILLING	7
5.1 VIEWING CABINET	7
5.2 PLACING	8
5.3 GRADING	8
5.4 EXAMPLE	9
6. FICTION COEFFICIENT	9
6.1 APPARATUS:	9
6.2 OPERATIONS.....	10
6.3 CALCULATION	11
6.4 EVALUATION	11

OPERATION OF YG511-III

1 Introduction

As the action of kneading and friction under washing or wearing, it is easy to get pilling and fuzzing on apparel surface. The pilling and fuzzing not only let appearance of apparel worse, but also reflect inner quality and wearing capability. There are many factors that affect the pilling and fuzzing properties of fabrics, such as fiber property, yarn, fabric structure, dyeing and finishing process, etc.

2. Test method

There are three types of test methods applied to assess the pilling and fuzzing properties of fabric, ORBITER, IMPULSE and MARTINDALE methods.

2.1 Orbiter method

Specimens are mounted on polyurethane tubes and tumbled randomly in a cork-lined box at a constant rotational speed. Fuzzing and pilling is assessed visually after a defined period of tumbling. Corresponding international standards are EN ISO 12945-1, BS 5811, IWS TM 152, etc.

Recommended testing machine by *FYI* is *YG511-III/IX Orbiter Pilling and Snagging Tester* (see figure 1).

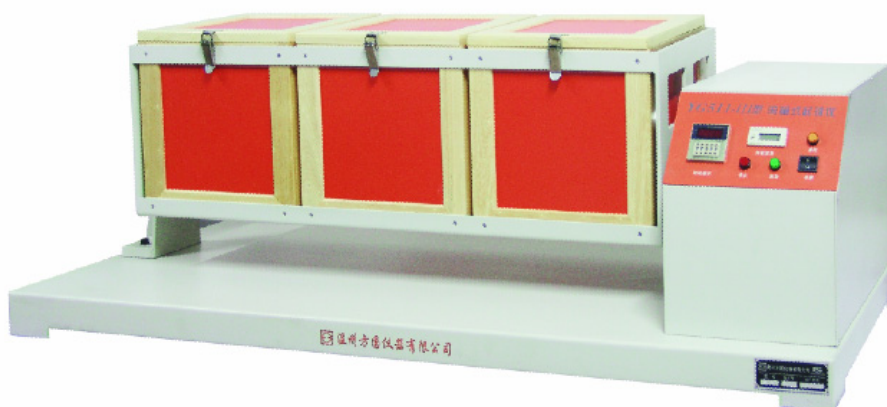

Figure 1—YG511-III/IX Orbiter Pilling and Snagging Tester



WWW.FYICHINA.COM.CN

WENZHOU FANGYUAN INSTRUMENT CO., LTD.
DOWELL SCIENCE AND TECHNOLOGY (HONGKONG) CO., LTD.
ADD: ROOM 1401 CAMBRIDGE HOUSE, 26-28 CAMERON ROAD,
TSIMSHATSUI, KL, HONGKONG
TEL: +86-755-83638931
Fax: +86-755-26747651

2.2 Martindale method:

A circular test specimen is passed over a friction surface comprising the same fabric or, when relevant, a wool abrasant fabric, at a defined force in the form of a Lissajous figure, with the test specimen able to rotate easily around an axis through its centre, perpendicular to the plane of the test specimen. Fuzzing and pilling are assessed visually after defined stages of rub testing. Corresponding international standards are ISO 12945-2, ASTM D4970, IWS TM 196, etc.

Recommended testing machine by *FYI* is *YG401D Digital Martindale Abrasion and Pilling Tester* (see figure 2).



Figure 2— YG401D Digital Martindale Abrasion and Pilling Tester

2.3 Impulse method

Specimen random tumbled in a cylinder with air pressure 200~800kPa. Pilling and fuzzing of specimen are produced by random friction between specimens and inner wall of cylinder. This testing method is suitable for tating and knotting fabrics. The corresponding international standards are ASTM D3512, DIN 53867, etc.

3 Preparation of test specimens

3.1 Cutting out

From the sample, cut four test specimens, each 125 mm×125 mm. On each test specimen mark the back of the fabric and the length direction. Where a fabric has no discernible face, test both sides. An additional cut specimen of 125 mm×125 mm is required for assessment.

3.2 Number of test specimens

Take two specimens and fold each with its face, if discernible, inward and with the machine direction running in the direction of the fold. Sew 12 mm from the cut edges to form a tube, using a stitch density such that a balanced seam is produced. Prepare the other two specimens similarly with the cross direction running in the direction of the fold.

3.3 Mounting of test specimens

Turn each specimen inside out, so that the fabric face forms the outside of a tube, and cut 6 mm off each end of the fabric tube to remove any sewing distortion. Mount one prepared specimen on each polyurethane specimen tube so that the specimen ends are an equal distance in from the ends of the polyurethane specimen tube (see Figure 3). Ensure that the seamed portion lies as flat as possible. **Apply self-adhesive PVC tape around each of the cut ends of each specimen, so that the tape fixes the specimen on to the tube and leaves 6 mm of the polyurethane specimen tube exposed.** The length of tape on each end of the specimen shall not exceed a length of approximately 1.5 times the circumference of the tube.



WWW.FYICHINA.COM.CN

WENZHOU FANGYUAN INSTRUMENT CO., LTD.
DOWELL SCIENCE AND TECHNOLOGY (HONGKONG) CO., LTD.
ADD: ROOM 1401 CAMBRIDGE HOUSE, 26-28 CAMERON ROAD,
TSIMSHATSUI, KL, HONGKONG
TEL: +86-755-83638931
Fax: +86-755-26747651

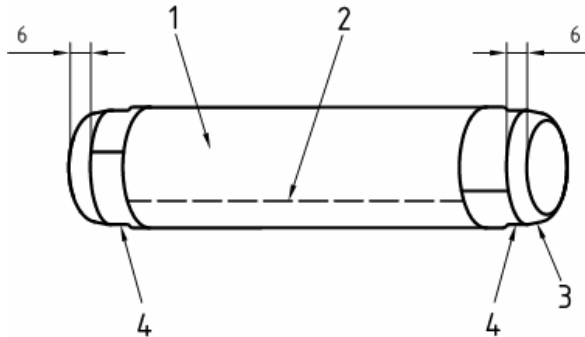

- 1 Test specimen
- 2 Seam
- 3 Polyurethane tube
- 4 Adhesive tape

Figure 3— Mounting of specimen on to polyurethane tube

3.4 Conditioning

Condition the specimens in the atmosphere specified with a temperature of $(20 \pm 2)^\circ\text{C}$ and a relative humidity of $(65 \pm 2)\%$ for at least 16 h. Carry out the test in the same atmosphere.

4. Test procedure

4.1 Checking

Check pilling boxes for impurities, if present, should clean it, not allow any wool impurities.

4.2 Loading specimen

Put every four specimens into one pilling boxes; lock it to avoid opening the lid of pilling boxes when rotating.



WWW.FYICHINA.COM.CN

WENZHOU FANGYUAN INSTRUMENT CO., LTD.
DOWELL SCIENCE AND TECHNOLOGY (HONGKONG) CO., LTD.
ADD: ROOM 1401 CAMBRIDGE HOUSE, 26-28 CAMERON ROAD,
TSIMSHATSUI, KL, HONGKONG
TEL: +86-755-83638931
Fax: +86-755-26747651

4.3 Power supply

Switch power on, and turn on the unit.

4.4 parameter setting

4.4.1 Counts reset

As turn of revolution saved after each testing, it's necessary to reset counts before the next testing. Press the button at up position on counts to reset the turn of revolutions (see figure 4).

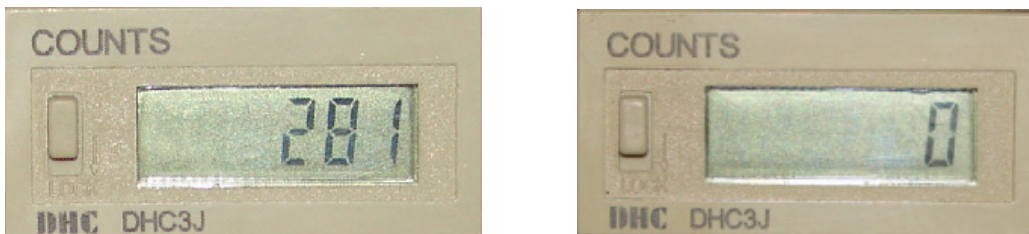

Figure 4—Resetting number of revolutions

4.4.2 Time preset

No test/wear predictions are available covering all types of textile fabrics. It is therefore necessary for the parties concerned to agree on the number of revolutions for the particular fabric construction under test. As to this machine, the number of revolutions per min is 60 ± 2 rpm. So the preset time is the total number of revolutions divided by 60 rpm.

Firstly, press 【复位/reset】 button on control panel to reset time showed on timer.

Secondly, dial “-” and “+” on timer to preset working time.

For example, if we want to set number of rotation is 7200r, the final panel of timer see figure 5,



WWW.FYICHINA.COM.CN

WENZHOU FANGYUAN INSTRUMENT CO., LTD.
DOWELL SCIENCE AND TECHNOLOGY (HONGKONG) CO., LTD.
ADD: ROOM 1401 CAMBRIDGE HOUSE, 26-28 CAMERON ROAD,
TSIMSHATSUI, KL, HONGKONG
TEL: +86-755-83638931
Fax: +86-755-26747651



Figure 5—Resetting working time

4.5 Notes

- When reach presetted times value, the instrument will stop automatically.
- Operator can press the key of 【停止/STOP】 to stop the tester when it's working. If need to continue, press the key 【启动/START】 , the test will accumulate the working time and number of revolutions.

4.6 Unload

Open pilling boxes, and take out specimen tubes, remove specimens from tubes, open seam, and then valuate the specimens under standard light resource.

5. Assessment of fuzzing and/or pilling

5.1 Viewing cabinet

Illuminated by a white fluorescent tube or bulb (the color temperature of the light source is not critical) to give uniform illumination over the width of the specimen(s) and masked in such a way that the observer does not look directly into the light. Position the illuminant at an angle between 5° and 15° to the plane of the specimen. The distance between the eye and the specimen shall be between 30 cm and 50 cm for normal corrected vision(see figure 6).

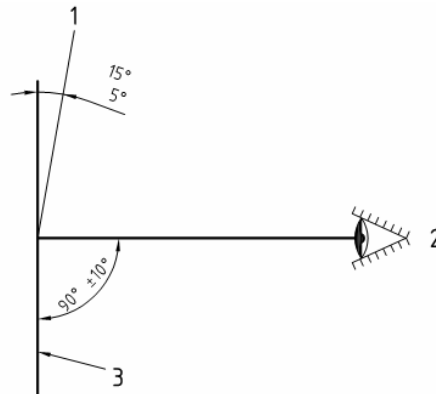

- 1 Light source
- 2 Observer
- 3 Specimen

Figure 6 — Illumination of specimens

5.2 Placing

Place the tested specimen and a piece of the original sample, centrally on the lectern in the viewing cabinet (see Figure 6), with the length direction vertical. Mount the tested specimen on the left and the original sample on the right.

5.3 Grading

Grade each specimen in accordance with the grading scheme given in Table 1. If the grading appears between two grades, report the “half” grading as, for example, 3-4.

Table 1 — Visual assessment

Grade	Description
5	No change.
4	Slight surface fuzzing and/or partially formed pills.
3	Moderate surface fuzzing and/or moderate pilling. Pills of varying size and density partially covering the specimen surface.
2	Distinct surface fuzzing an/or distinct pilling. Pills of varying size and



WWW.FYICHINA.COM.CN

WENZHOU FANGYUAN INSTRUMENT CO., LTD.
DOWELL SCIENCE AND TECHNOLOGY (HONGKONG) CO., LTD.
ADD: ROOM 1401 CAMBRIDGE HOUSE, 26-28 CAMERON ROAD,
TSIMSHATSUI, KL, HONGKONG
TEL: +86-755-83638931
Fax: +86-755-26747651

	density covering a large proportion of the specimen surface.
1	Dense surface fuzzing and/or severe pilling. Pills of varying size and density covering the whole of the specimen surface.

5.4 Example

Following figure(see figure 7) is a comparison between tested specimen (terylene) after 2 hours of tumbling (about 7200 turns) and original sample, The tested specimen with a slight surface fuzzing, and the fuzzing is not easy to observable, so the grading appears between two grades, 4~5.



Figure 7—Comparing between tested specimen (left) and original sample (right)

6. Fiction coefficient

New liners require running in for approximately 200h with four blank tubes until the liner has stopped shedding cork dust.

6.1 Apparatus:

- A.. Wood block with dimension 115mm×55mm×15mm and weight 55g, and string.
- B. Weight: 200g, and others.



WWW.FYICHINA.COM.CN

WENZHOU FANGYUAN INSTRUMENT CO., LTD.
DOWELL SCIENCE AND TECHNOLOGY (HONGKONG) CO., LTD.
ADD: ROOM 1401 CAMBRIDGE HOUSE, 26-28 CAMERON ROAD,
TSIMSHATSUI, KL, HONGKONG
TEL: +86-755-83638931
Fax: +86-755-26747651

C. Block and tackle.

6.2 Operations

A. Keep cork liners on a horizontal plane.

B. Install wood block, 200g weight, block and tackle as figure 8,

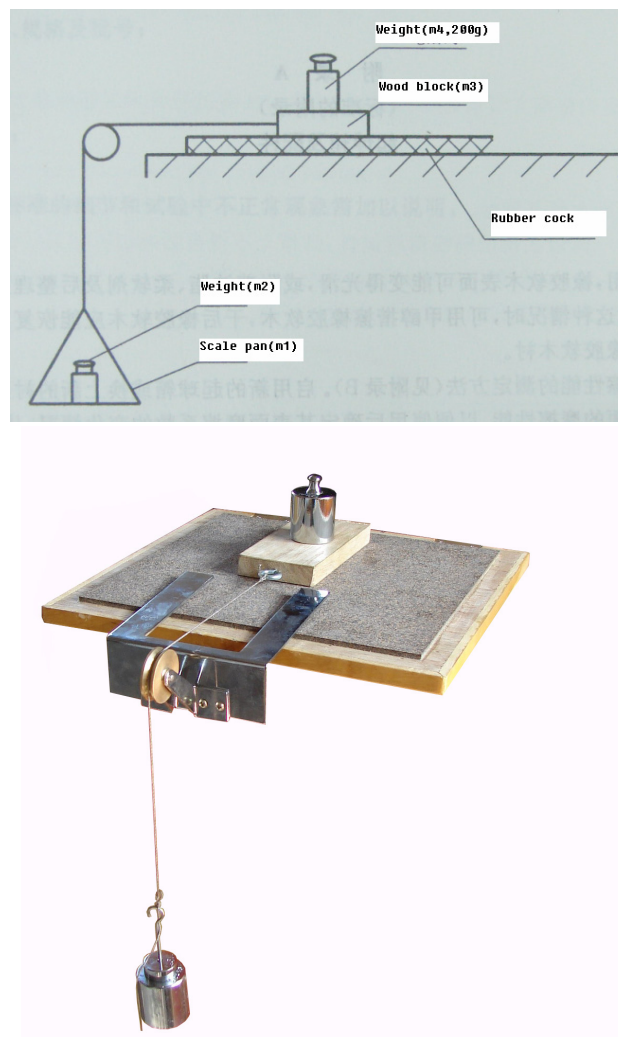

Figure 8—Measuring friction efficient of cork

C. Hang weights on a hook at the other end of string.

D. Add weights until the wood block starts to move with constant speed on tested cork.



WWW.FYICHINA.COM.CN

WENZHOU FANGYUAN INSTRUMENT CO., LTD.
DOWELL SCIENCE AND TECHNOLOGY (HONGKONG) CO., LTD.
ADD: ROOM 1401 CAMBRIDGE HOUSE, 26-28 CAMERON ROAD,
TSIMSHATSUI, KL, HONGKONG
TEL: +86-755-83638931
Fax: +86-755-26747651

6.3 Calculation

Friction coefficient C_F :

$$C_F = \frac{m_1}{m_2 + m_3}$$

Where m_1 is the mass of lower weight; m_2 is the mass of wood block; m_3 is the mass of weight on wood block.

6.4 Evaluation

FYI Opinion

If $C_{F1} < 0.5C_{F0}$, Pilling box should be changed or do some cleaning.

If $C_{F1} < 0.5C_{F0}$, It is still under acceptable working condition.

C_{F0} original Friction coefficient before first use

C_{F1} after a period of use, Actual Friction coefficient

ISO Opinion

Generally, the frictional properties of the cork are not a major source of test result variation, but after prolonged use the surface of the cork may become polished or contaminated. Such changes can lead to less severe pill testing.